



**ATHENA &  
OLYMPIA**

TRAY SEALERS

TERMOSIGILLATRICI



# ATHENA

AUTOMATIC TRAY SEALER



EFFETTO SKIN  
SKIN EFFECT

**STAMPO INTERSCAMBIABILE  
INTERCHANGEABLE MOULD**



TAGLIO INTERNO  
INSIDE CUT



# OLYMPIA

SEMI-AUTOMATIC TRAY SEALER

**ATHENA**  
La sigillatrice automatica modello Athena è in grado di confezionare in atmosfera protettiva qualsiasi combinazione compatibile di vaschette e film di copertura studiati per tale applicazione. La robusta struttura in acciaio inossidabile, la facilità di manutenzione e la rispondenza ai requisiti igienici previsti dalla legge insieme alla possibilità di utilizzare gli stampi della sigillatrice semiautomatica Olympia, la rendono una macchina adatta ad ogni tipo di utilizzo sia per le piccole che per le medie aziende.

**ATHENA**  
The automatic sealing machine model Athena is capable of packaging in modified atmosphere any combination of compatible trays and top film studied for such applications. Thanks to the Athena's strong stainless steel structure, easy maintenance and conformity to hygienic requirements, this machine is ideal for use in small and medium sized companies. One of the more important aspects of this machine is the possibility to use the moulds of the semi-automatic machine model Olympia on the Athena.

**ATHENA**  
Der automatische Schalenriegler Modell Athena eignet sich zum verschließen aller im Markt erhältlichen siegelfähigen Schalen/Folie Kombinationen unter Schutzatmosphäre. Eine robuste Edelstahlstruktur, eine wartungsfreundliche und hygienegerechte Bauweise, sowie die Möglichkeit das Werkzeug des halb-automatischen Schalenrieglers Olympia zu nutzen, machen diese Maschine besonders effizient und profitabel für alle Anwendungen in Klein- und Mittelbetrieben.

**ATHENA**  
La scelleuse automatique modèle Athena est en mesure d'effectuer le conditionnement sous atmosphère modifiée de toute combinaison compatible de barquettes et films d'operculation conçus pour cette application. Le solide bâti en acier inox, l'entretien aisé, la conformité aux exigences d'hygiène prévues par la loi, ainsi que l'interchangeabilité de son moule avec celui de la scelleuse semi-automatique Olympia, en font une machine flexible spécialement adaptée aux petites et moyennes entreprises.

**ATHENA**  
La selladora automática modelo Athena es capaz de embalar en atmósfera modificada cualquier combinación compatible de tanques y película de cobertura estudiados para dicha aplicación. La robusta estructura de acero inoxidable, la facilidad de mantenimiento y la aptitud a los requisitos higiénicos previstos por la ley junto con la posibilidad de utilizar los moldes de la selladora semiautomática Olympia, la hacen una máquina apropiada a cada tipo de uso tanto para las pequeñas como para las medias empresas.

## STAMPI/MOULDS H120

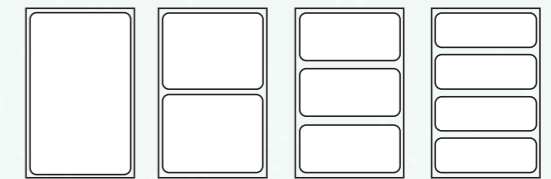

	1 CAV.	2 CAV.	3 CAV.	4 CAV.
ATHENA VG	287x424	201,5x287 287x209,5*	287x127	90,25x287 287x98,25**
ATHENA S	285x464	221,5x285 285x229,5*	285x140,5	100,25x285 285x108,25**

\* fustelle unite / jointed cutting knives  
\*\* fustelle unite a 2 a 2 / jointed cutting knives 2 by 2

## LAY-OUT

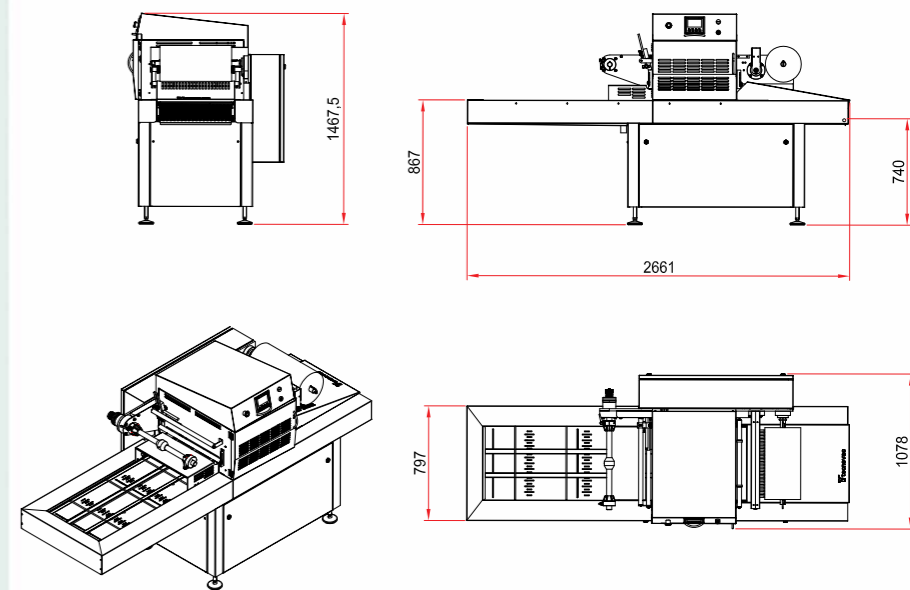



# ATHENA XL

AUTOMATIC TRAY SEALER



Pannello di controllo/  
Touch panel

## STAMPI/MOULDS H120

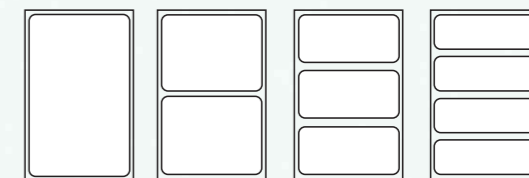

	1 CAV.	2 CAV.	3 CAV.	4 CAV.
ATHENA XL VG	357x424	357x201 357x209,5*	357x127	357x90,25 357x98,25**
ATHENA XL S	355x464	355x221,5 355x229,5*	355x140,6	355x100,25 355x108,25**

\* fustelle unite / jointed cutting knives

\*\* fustelle unite a 2 a 2 / jointed cutting knives 2 by 2



Ip 67 protection/IP 67 protection

Disimpilatore/Denester



Prolunga/Extra infeed



Dettaglio stampo/Mould detail



# ATHENA DUAL DRIVE

AUTOMATIC TRAY SEALER



## ATHENA DUAL DRIVE

Soluzione integrata che unisce produttività e flessibilità in un'unica macchina. La soluzione adottata sulla nuova ATHENA DUAL DRIVE (doppie campane completamente indipendenti e separate dal punto di vista di movimentazione inferiori e cicli film) garantisce migliori performance quali:

**DOPPIA PRODUTTIVITA':** Utilizzando 2 stampi identici si può incrementare la produttività ottenendo allo stesso tempo un minore spreco di film (non vi è scarto di film compreso tra le vaschette delle due campane)

**ALTA FLESSIBILITA':** E' possibile montare 2 stampi differenti e utilizzare alternativamente (o l'una o l'altra) le due campane mantenendo entrambi gli stampi caldi e pronti per l'uso; possibilità di montare 2 fasce film differenti diminuendo il consumo di film

**SKIN + SIGILLATURA:** Possibilità di eseguire due operazioni consecutive quali sigillatura skin + sigillatura tradizionale contemporaneamente in un'unica passata in macchina.

**ATHENA DUAL DRIVE**, the absolute novelty in the tray sealing field, is the integrated solution able to guarantee Productivity and Flexibility with one single machine. The solution offered by the new ATHENA DUAL DRIVE (two independent chambers with separate lower lifting and film unwind/rewind systems) can guarantee the following performance improvements:

### DOUBLE PRODUCTIVITY

Productivity can be increased by using 2 identical moulds. At the same time the machine allows the reduction of the waste film (no waste film in the area between the two chambers).

### HIGH FLEXIBILITY

The machine allows the packing of trays with two different tools since the two chambers can work alternatively. Both tools can remain constantly heated and therefore always ready-to-use.

### SKIN + TOP SEAL APPLICATION

The machine offers the possibility of performing Skin + Standard Top Seal application without manual operations and changeovers and with only one passage of the trays into the machine.

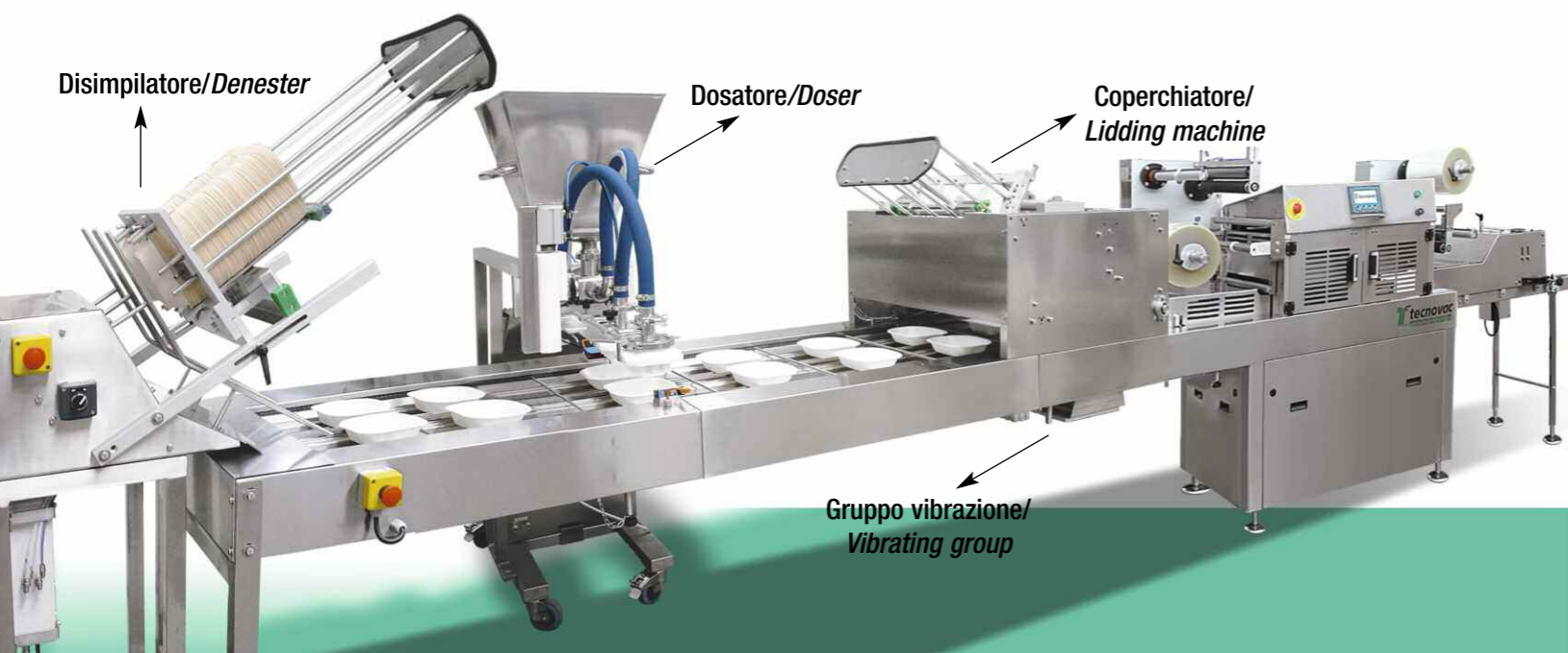

## ATHENA DUAL DRIVE

Durch zwei unabhängige Folienführungen gewährleistet der neuen Schalensiegler Modell ATHENA DUAL DRIVE maximale Flexibilität bei bewährter Tecnovac Qualität. Die Maschine bietet die folgenden Möglichkeiten:

- Doppelkammer Werkzeug mit schneller Einformatanwendung
- Produktion mit zwei verschiedenen Formaten
- Skin mit anschließender Top Seal Anwendung INLINE in einem Doppelkammer Werkzeug

**DIE VORTEILE DIESER MASCHINE LIEGEN KLAR AUF DER HAND:**

- Geringerer Folienverlust bei Doppelkammer Einformatanwendungen
- Weniger Umrüstphasen
- Keine Handarbeit mehr beim Umsetzen von Skin Schalen die top gesealt werden müssen
- Höhere Effizienz am Ende der Produktion
- Maximale Flexibilität in Ihrem Markt

Diese Maschine rechnet sich in der Produktion und gibt Ihnen die Möglichkeit noch flexibler auf Ihre Kundenbedürfnisse einzugehen.

## ATHENA DUAL DRIVE

Avec ses deux enrouleurs de lisière indépendants, la nouvelle operculeuse ATHENA DUAL DRIVE combine une plus grande flexibilité avec la qualité prouvée de Tecnovac.

- Cette machine offre les possibilités suivantes:
- Même outillage en double chambre avec système de changement rapide des moules
  - Production avec deux formats différents
  - Skin et scellage INLINE grâce aux deux chambres

### Les avantages de cette machine sont évidents:

- Gain des déchets de film en utilisant deux outillages identiques dans les deux chambres
- Gain au temps de changement d'outillage
- Aucun travail manuel pour operculer des barquettes skin
- Amélioration de l'efficacité en fin de ligne
- Grande flexibilité sur votre marché

Cette machine va se distinguer dans votre production et elle vous donne la chance de répondre d'une façon encore plus flexible aux exigences de vos Clients.

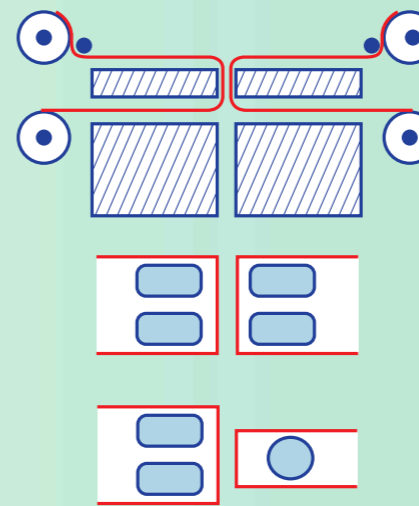

Gestione film superiore/Top film handling

## STAMPI/MOULDS H120



	1 CAV.	2 CAV.	3 CAV.	4 CAV.
ATHENA VG	2x287x424	2x201,5x287 2x287x209,5*	2x287x127	2x90,25x287 2x287x98,25**
ATHENA S	2x285x464	2x221,5x285 2x285x229,5*	2x285x140,5	2x100,25x285 2x285x108,25**

\* fustelle unite / jointed cutting knives

\*\* fustelle unite a 2 a 2 / jointed cutting knives 2 by 2

## LAY-OUT

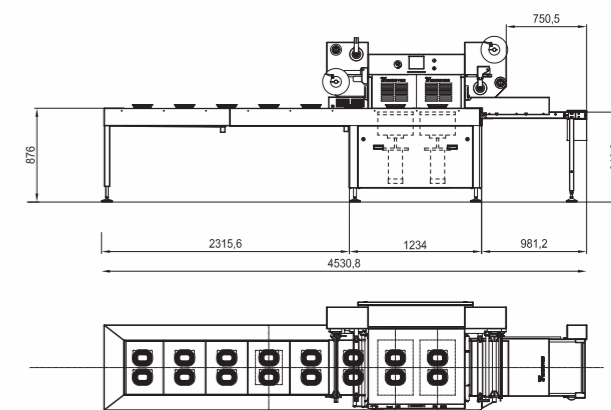
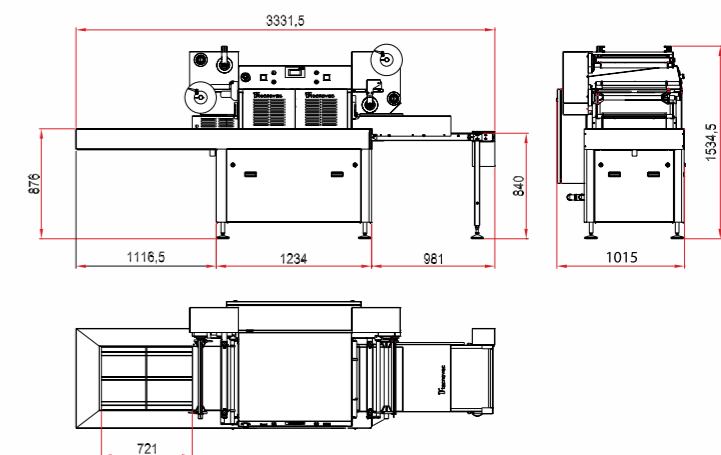



# ATHENA H250

AUTOMATIC TRAY SEALER



## STAMPI/MOULDS H250

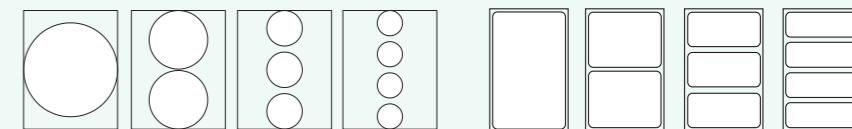

	1 CAV.	2 CAV.	3 CAV.	4 CAV.
<b>ATHENA VG</b>	357x424	357x201 357x209,5*	357x127	357x90,25 357x98,25**
<b>ATHENA S</b>	355x464	355x221,5 355x229,5*	355x140,6	355x100,25 355x108,25**

\* fustelle unite / jointed cutting knives

\*\* fustelle unite a 2 a 2 / jointed cutting knives 2 by 2

## LAY-OUT

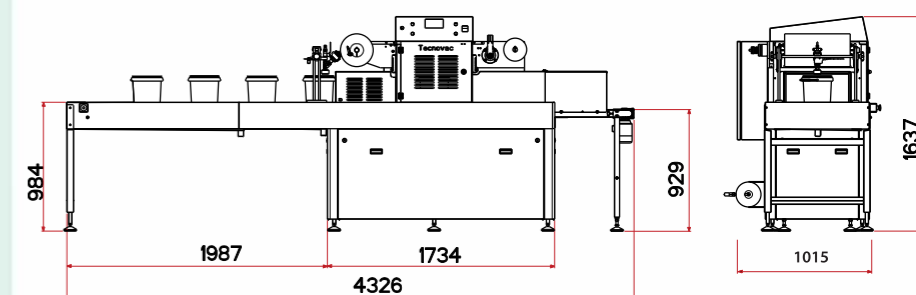

Dettaglio ginocchiera/Cantilever detail



Esempio di dosatore/Dosing unit example

Modello/Model/Modell/Modelo	ATHENA	ATHENA XL	ATHENA Dual Drive	ATHENA H250
Dimensioni macchina / Machine dimensions / Abmessungen der Maschine Dimensions de la machine / Dimensiones maquina	2674,5x1015x1402 h mm	2674,5x1015x1402 h mm	3331,5x1015x1534,5 h mm	4326x1015x1637 h mm
Zona di carico / Loading area / Lade Bereich / Plane de chargement / Zona de carga	750 mm	750 mm	900 mm	1987 mm
Altezza di lavoro / Working height / Arbeitshöhe / Hauteur de travail / Altura de trabajo	900 mm	900 mm	900 mm	984 mm
Peso indicativo macchina / Approx. Weight / Gewicht (ungefähr) Poids approximatif / Peso aproximado	600 kg	650 kg	800 kg	700 kg
Produzione sino a / Production up to / Produktion bis zu Production jusqu'à / Producción hasta	15 cicli/min.	15 cicli/min.	15 cicli/min.	15 cicli/min.
Fascia film max. - D. max. film - Mandrino / Max. film width - Max. film diameter - Mandrel / Max. Breite der Folie - Max. Rollendurchmesser - Folienrolle / Laize max. du film - Diamètre max. de la bobine - Mandrin / Ancho max. film - Diametro Max. bobina - Mandril	480/250/76 mm	480/250/76 mm	480/250/76 mm	480/250/76 mm
Pompa vuoto con sensore* / Vacuum pump with digital vacuum gauge* / Vakuumpumpe mit Vakuumsensor* / Pompe à vide avec vacuomètre digital* / Bomba de vacío y sensor*	100 mc/h*	100 mc/h*	200 mc/h* esterna/outside the machine	100 mc/h*
Dispositivo gas neutro con accumulatore / Gas flushing appliance with gas tank / Vorrichtung Begasung mit gastank / Dispositif réinjection de gaz avec réservoir gaz / Dispositivo gas y tanque	standard	standard	standard	standard
10 programmi memorizzabili / 10 programs to store / 10 speicherbare Programme 10 programmes mémorisables / 10 programas	standard	standard	standard	standard
Aria Compressa** / Compressed air** / Druckluft** / Air comprimé** / Consumo de aire**	160 - 500 NI/min 6 bar**	160 - 500 NI/min 6 bar**	300 - 900 NI/min 6 bar**	400 NI/min 6 bar**
Alimentazione standard / Power supply / Stromversorgung / Raccordement électrique / Voltaje	400V trifase, 50 Hz neutro e terra TN-S	400V trifase, 50 Hz neutro e terra TN-S	400V trifase, 50 Hz neutro e terra TN-S	400V trifase, 50 Hz neutro e terra TN-S
Potenza elettrica fino a / Power consumption up to / Elektrische Leistungsaufnahme bis zu / Consommation électrique à / Potencia electrica hasta	4,5 Kw max.	5,3 Kw max.	9 Kw max.	5,5 Kw max.

Materiali: vaschette preformate saldabili di mono o bicomponente, laminato, espanso, cartone ed alluminio con strato saldabile. / Materials: preformed sealable trays mono or bi-component, laminated, foam, cardboard and aluminium with sealable layer. / Material: vorgefertigte, siegelfähige Trays aus Mono- oder Verbundfolien, auch Schaummaterial, Karton- und Aluminiumtrays mit siegelfähiger Schicht. / Matériaux : barquettes scellables préformées mono ou bi-composant, en laminé, mousse, carton et aluminium avec couche scellable. / Materiales: tanques preformados soldables de uno o dos componentes, laminado, espuma, cartón y aluminio con capa soldable.

# OLYMPIA

SEMIAUTOMATIC TRAY SEALER



OPTIONAL: Sollevamento automatico vaschetta e cassetto/  
Pneumatic drawer opening for tray lifting

## OLYMPIA basic



## OLYMPIA H 250

Con recupero film automatico/  
Whit automatic waste film rewind

## STAMPI/MOULDS H140

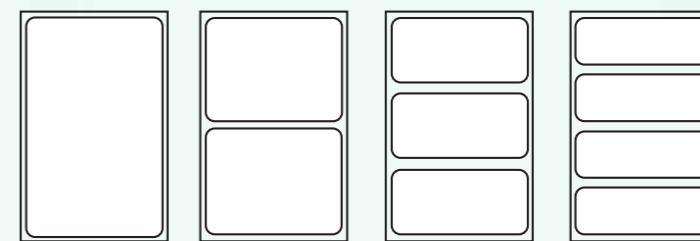

	1 CAV.	2 CAV.	3 CAV.	4 CAV.
<b>OLYMPIA VG/S</b> manuale/hand operating	275x424	275x201,5 127x424	275x127,35 77,5x424	275x90,25 127x201,5
<b>OLYMPIA VG/S</b> riav. automatico/ automatic film rew	266x457	266x218 122,5x457	266x138,35	266x98,52 122,5x218

\* fustelle unite / jointed cutting knives

\*\* fustelle unite a 2 a 2 / jointed cutting knives 2 by 2

### Modello/Model/Modell/Modelo

	OLYMPIA BASIC	OLYMPIA recupero film automatico/ automatic waste film rewind	OLYMPIA H250
Dimensioni macchina / Machine dimensions / Abmessungen der Maschine Dimensions de la machine / Dimensiones maquina	587x851x1326 h mm	728x935x1575 h mm	728x935x1675 h mm
Altezza di lavoro / Working height / Arbeitshöhe / Hauteur de travail / Altura de trabajo	880 mm	880 mm	975 mm
Peso indicativo macchina / Approx. Weight / Gewicht (ungefähr) Poids approximatif / Peso aproximado	200 kg	230 kg	250 kg
Produzione sino a / Production up to / Produktion bis zu Production jusqu'à / Producción hasta	5 cicli/min.	5 cicli/min.	5 cicli/min.
Fascia film max. - D. max. film - Mandrino / Max. film width - Max. film diameter - Mandrel / Max. Breite der Folie - Max. Rollendurchmesser - Folienrolle / Laize max. du film - Diamètre max. de la bobine - Mandrin / Ancho max. film - Diametro Max. bobina - Mandril	480/15 Kg max.	310/250/76 mm	310/250/76 mm
Pompa vuoto con sensore* / Vacuum pump with digital vacuum gauge* / Vakuumpumpe mit Vakuumsensor* / Pompe à vide avec vacuomètre digital* / Bomba de vacío y sensor*	40/60 mc/h*	40/60 mc/h*	40/60 mc/h*
10 programmi memorizzabili / 10 programs to store / 10 speicherbare Programme 10 programmes mémorisables / 10 programas	standard	standard	standard
Aria Compressa** / Compressed air** / Druckluft** / Air comprimé** / Consumo de aire**	2 NI/ciclo-cycle 6 bar**	2 NI/ciclo-cycle 6 bar**	2 NI/ciclo-cycle 6 bar**
Alimentazione standard / Power supply / Stromversorgung / Raccordement électrique / Voltaje	400V trifase, 50 Hz neutro e terra TN-S	400V trifase, 50 Hz neutro e terra TN-S	400V trifase, 50 Hz neutro e terra TN-S
Potenza elettrica fino a / Power consumption up to / Elektrische Leistungsaufnahme bis zu / Consommation électrique à / Potencia electrica hasta	2,5 Kw max.	2,5 Kw max.	2,5 Kw max.

Materiali: vaschette preformate saldabili di mono o bicomponente, laminato, espanso, cartone ed alluminio con strato saldabile. / Materials: preformed sealable trays mono or bi-component, laminated, foam, cardboard and aluminium with sealable layer. / Material: vorgefertigte, siegelfähige Trays aus Mono- oder Verbundfolien, auch Schaummaterial, Karton- und Aluminiumtrays mit siegelfähiger Schicht. / Matériaux : barquettes scellables préformées mono ou bi-composant, en laminé, mousse, carton et aluminium avec couche scellable. / Materiales: tanques preformados soldables de uno o dos componentes, laminado, espuma, cartón y aluminio con capa soldable.

OLYMPIA



TECNOVAC si riserva la facoltà di apportare qualsiasi modifica senza alcun preavviso/Any improvement may be subject to change without notice/Recht auf Änderungen Spezifikationen vorbehalten/Mous réservés la faculté d'apporter à nos constructions ou données amélioration/TECNOVAC se reserva el derecho de modificar sin previo aviso. \*La pompa standard non può lavorare con un % di O<sub>2</sub> > 21%/\*The standard pump cannot work with % of O<sub>2</sub> > 21%/\*La pompe à vide ne peut pas travailler avec un % de O<sub>2</sub> > 21%/\*Die standardvakuumpumpe kann nicht mit einem % O<sub>2</sub> von Sauerstoff über 21%/\*La bomba estándar no puede trabajar con un % de O<sub>2</sub> > 21%. \*Il compressore non è inclusivo/\*The compressor is not included/\*Der druckluftkompressor ist nicht inbegriffen/\*El compresor no está incluido.

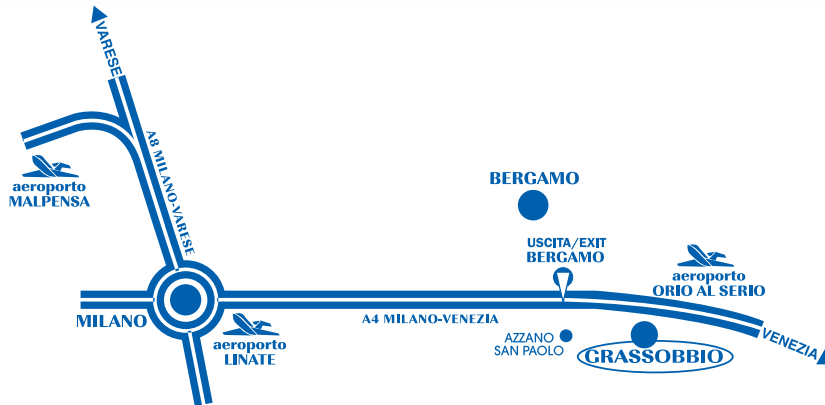

## HEADQUARTER

Via Padre Elzi, 28/C  
24050 GRASSOBBIO (BG)  
ITALY

Tel. (+39) 035 3846801/02/03 - (+39) 035 534074  
Fax (+39) 035 534076



## USA

2106-C Cheshire Way  
Greensboro, NC 27405  
USA  
Tel. (+1) 336-375-8822  
Fax (+1) 336-464-2330

## ARGENTINA

Luis Saenz Peña 1831 planta alta  
CP 1131  
ARGENTINA  
Tel. (54-11) 4304-2845

## BRASILE

Alameda Rio Negro, 1030 -  
Sala 1904 - Alphaville  
06454-000 Barueri - SP  
BRASIL  
Tel. (+55) 11 4688 0682/11 98588 5176  
Fax (+55) 11 4689 1161

## MIDDLE EAST

205 Christodoulou Hadjipavlou Str  
Loulloupis Court - 5th Floor, Office 501  
3036 Limassol  
CYPRUS  
Mobile: (+961) 3253741