

7/ *tecnovac*

MACCHINE CONFEZIONATRICI SOTTOVUOTO
VACUUM PACKAGING MACHINES



tecnovac
CONFEZIONATRICI PACKAGING MACHINES
P.035.534074 - WWW.TECNOVAC.COM

ORION

**TERMOSIGILLATRICI
TRAY SEALERS**



ORION

AUTOMATIC TRAY SEALER

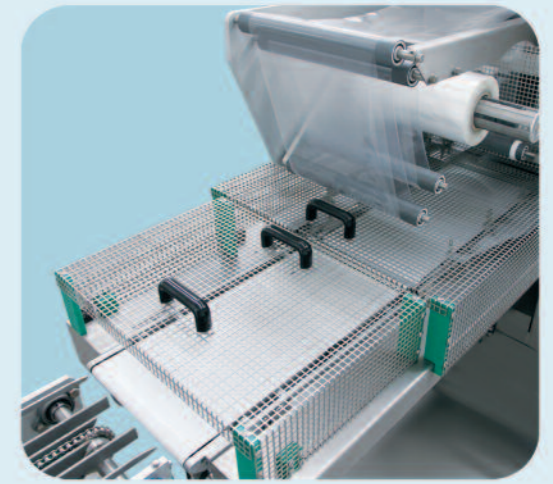

IP 67 PROTECTION

product. The modular configuration favours the integration of weighing and dosing systems, de-nesters, lidding machines and printers. A reliable and efficient solution for high capacity production.

ORION

Der Schalensiegler Modell Orion ist ein robuster und zuverlässiger Vollautomat, der bediener- und wartungsfreundlich, sowie hygienegerecht gestaltet ist. Ein effizientes Vakuum- und Begasungssystem verbunden mit einer präzisen Regelung vom Schalentransport bis hin zur Siegeleinheit, garantieren optimale Verpackungsergebnisse. Optionen wie Inside Cut oder Skin Verpackung sichern Ihre Flexibilität im Markt hinsichtlich der Produktpräsentation. Der modulare Aufbau erlaubt zudem problemlos die Integration von Wiege- und Dosiersystemen, Entstaplern, Verdecklern und Druckern. Eine zuverlässige und profitable Lösung für jede industrielle Produktion.

ORION

La scelleuse automatique modèle Orion est une machine solide et fiable. Très simple à utiliser et entretenir, elle satisfait toutes les exigences d'hygiène prescrites par la loi. Un système de conditionnement sous atmosphère modifiée très efficace et un réglage du transport des barquettes jusqu'à la cloche de scellage très précis, garantissent un résultat optimal. De plus, grâce à des options comme inside cut et skin, la machine est en mesure de satisfaire parfaitement les exigences les plus variées de présentation du produit. La configuration modulaire favorise l'intégration de systèmes de pesage et dosage, dépileurs, operculeuses et imprimantes. Une solution fiable et efficace pour la production industrielle.

ORION

La selladora automática modelo Orion es robusta y fiable. El uso y el mantenimiento son muy simples y la máquina satisface todos los requisitos higiénicos previstos por la ley. El eficiente sistema para el empaquetado en atmósfera modificada, unido a una precisa regulación del transporte tanques hasta la campana de sellado, garantizan resultados óptimos. Gracias a opciones como el corte interno y el empaquetado Skin, la máquina es capaz de satisfacer perfectamente cada exigencia unida a la presentación del producto. La configuración modular favorece la integración de sistemas de pesado y dosificación, desamontonadores, tapadores e impresoras. Una solución fiable y eficiente para producciones de nivel industrial.

ORION

La sigillatrice automatica modello Orion è robusta ed affidabile. L'utilizzo e la manutenzione sono molto semplici e la macchina soddisfa tutti i requisiti igienici previsti dalla legge. L'efficiente sistema per il confezionamento in atmosfera protettiva, unito ad una precisa regolazione del trasporto vaschette fino alla campana di sigillatura, garantiscono risultati ottimali. Grazie ad opzioni quali il taglio interno ed il confezionamento Skin, la macchina è perfettamente in grado di soddisfare ogni esigenza legata alla presentazione del prodotto. La configurazione modulare favorisce l'integrazione di sistemi di pesatura e dosaggio, disimpilatori, coperchiatori e stampanti. Una soluzione affidabile ed efficiente per produzioni a livello industriale.

ORION

The automatic sealing machine model Orion is strong and reliable. It is extremely easy to use and its maintenance is very simple. The machine is made according to all the requirements foreseen by the laws on hygiene. The efficient system of packaging in Modified Atmosphere, together with the precision in conveying the trays to the sealing chamber, guarantee excellent results. Thanks to options such as incut and skin effect, the machine is perfectly capable of satisfying any need tied to the presentation of the

LAY-OUT

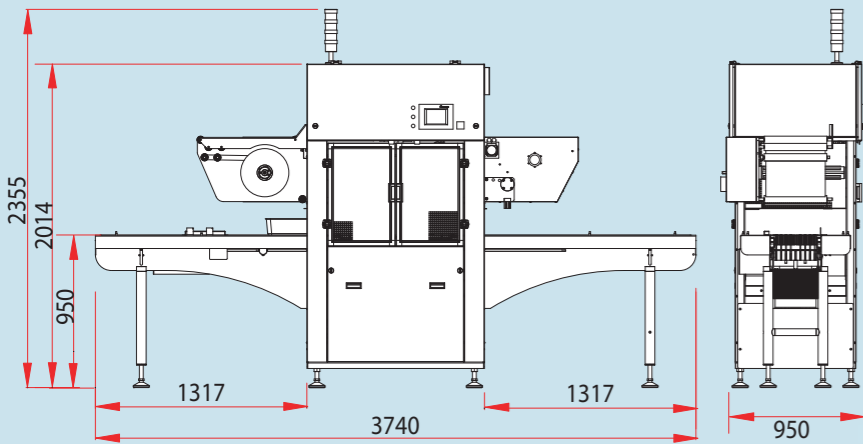

STAMPI/MOULDS

ORION

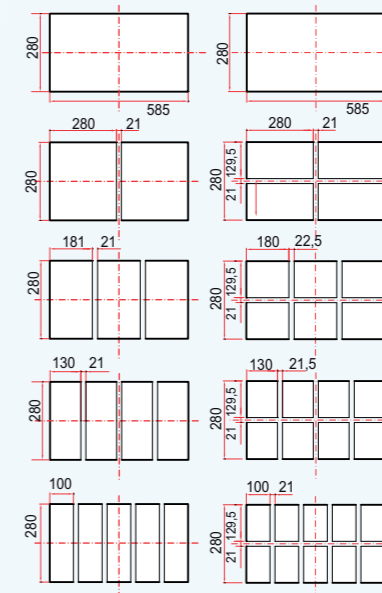

ORION XL

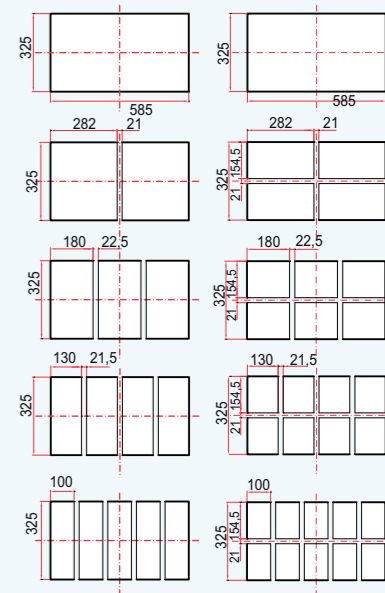

ORION MAXI

AUTOMATIC TRAY SEALER



ORION MAXI
 Der Hochleistungsschalensiegler Modell Orion Maxi ist mit seinen größeren Werkzeugabmaßen die Steigerung der Orion für anspruchsvollste Kunden. Ob Großkammerschalen oder Vielfachnutzen zur Produktivitätssteigerung, diese Maschine wird auch schwierigsten Kundenanforderungen gerecht. Mit allen Vorteilen und Integrationsmöglichkeiten der Orion versehen, garantiert Ihnen auch diese Maschine durch die hohen Qualitätsanforderungen der Firma Tecnovac einen maximalen Kundennutzen.

ORION MAXI
 La scelleuse haute productivité modèle Orion Maxi monte le moule le plus grand de la gamme Tecnovac et représente l'évolution du modèle Orion destiné aux Clients les plus exigeants. Qu'elle soit utilisée pour le conditionnement de grandes barquettes ou de plusieurs barquettes dans le même moule afin d'augmenter sa productivité, cette machine saura satisfaire même les demandes les plus complexes. Orion Maxi assure tous les avantages et les possibilités d'intégration du modèle Orion de base et, grâce à la qualité élevée Tecnovac, elle garantit une excellente flexibilité de production.

ORION MAXI
 La selladora para altas productividades modelo Orion Maxi monta el molde más grande de la gama Tecnovac y representa la evolución de Orion dedicada a los clientes más exigentes. Tanto si se utiliza para embalar tanques muy grandes como cavidades múltiples para aumentar la productividad, esta máquina es capaz de satisfacer también las exigencias más complejas. Presentando todas las ventajas y las posibilidades de integración del modelo base Orion y gracias a los altos estándares cualitativos Tecnovac, también esta máquina garantiza alta flexibilidad para cada tipo de uso.

LAY-OUT

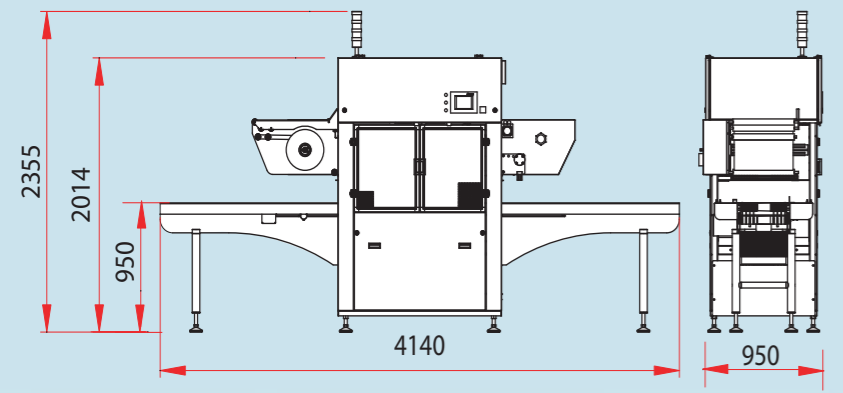

ORION MAXI
 La sigillatrice per alte produttività modello Orion Maxi monta lo stampo più grande della gamma Tecnovac e rappresenta l'evoluzione della Orion dedicata ai Clienti più esigenti. Sia che venga utilizzata per confezionare vaschette molto grandi che nel caso di cavità multiple per aumentare la produttività, questa macchina è in grado di soddisfare anche le richieste più complesse. Presentando tutti i vantaggi e le possibilità di integrazione del modello base Orion e grazie agli alti standard qualitativi Tecnovac, anche questa macchina garantisce alta flessibilità per ogni tipo di utilizzo.

ORION MAXI
 The automatic sealing machine model Orion Maxi for high capacity has the largest mould in the Tecnovac range and represents the evolution of the Orion for those customers in need of a higher productivity. Whether it be used for the packaging of very large trays or for moulds with several cavities in order to increase productivity, this machine can satisfy even the most complex requests. The machine guarantees a high flexibility for any type of use due to all the advantages and possibilities of integrating the basic model of the Orion and thanks to Tecnovac's high quality standards.

STAMPI/MOULDS

ORION MAXI

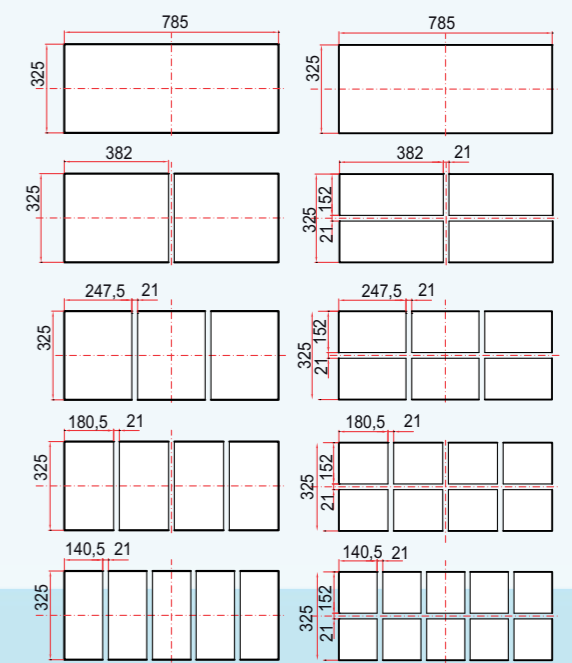

ORION LINES



LINEA PER
AFFETTATI IN
CAMERA BIANCA

LINE FOR COLD
CUTS IN COOL
ROOM



ORION IN DOPPIA
LINEA PER CARNE

DOUBLE LINE
ORION FOR MEAT

LINEA PER
VERDURA

LINE FOR
VEGETABLES



LINEA PER
CARNE

LINE FOR
MEAT



Modello/Model/Modell/	ORION	ORION XL	ORION MAXI
Dimensioni macchina / Machine dimensions / Abmessungen der Maschine Dimensions de la machine / Dimensiones maquina	3740x885x2355 h mm	3740x885x2355 h mm	4140x950x2355 h mm
Zona di carico / Loading area / Lade Bereich / Plane de chargement / Zona de carga	950 mm	950 mm	950 mm
Peso indicativo macchina / Approx. Weight / Gewicht (ungefähr) Poids approximatif / Peso aproximado	1000 kg	1000 kg	1100 kg
Produzione sino a / Production up to / Produktion bis zu Production jusqu'à / Producción hasta	18 cicli/min.	18 cicli/min.	18 cicli/min.
Fascia film max. - D. max. film - Mandrino / Max. film width - Max. film diameter - Mandrel / Max. Breite der Folie - Max. Rollendurchmesser - Foliendiameter / Laize max. du film - Diamètre max. de la bobine - Mandrin / Ancho max. film - Diametro Max. bobina - Mandril	320/350/76 mm	320/350/76 mm	360/350/76 mm
Pompa vuoto con sensore* / Vacuum pump with digital vacuum gauge* / Vakuumpumpe mit Vakuumsensor* / Pompe à vide avec vacuomètre digital* / Bomba de vacío y sensor*	300 mc/h*	300 mc/h*	300 mc/h*
Comandi digitali a touch screen / Touch screen panel / Touch screen / Ecran tactile / Panel digital touch screen	standard	standard	standard
Dispositivo gas neutro con accumulatore / Gas flushing appliance with gas tank / Vorrichtung Begasung mit gastank / Dispositif réinjection de gaz avec réservoir gaz / Dispositivo gas y tanque	standard	standard	standard
10 programmi memorizzabili / 10 programs to store / 10 speicherbare Programme 10 programmes mémorisables / 10 programas	standard	standard	standard
Aria Compressa** / Compressed air** / Druckluft** / Air comprimé** / Consumo de aire**	500 NI/min 6 bar**	500 NI/min 6 bar**	600 NI/min 6 bar**
Alimentazione / Power supply / Stromversorgung / Raccordement électrique / Voltaje	400V - 50Hz 3ph + neutro	400V - 50Hz 3ph + neutro	400V - 50Hz 3ph + neutro
Potenza elettrica fino a / Power consumption up to / Elektrische Leistungsaufnahme bis zu / Consommation électrique à / Potencia electrica hasta	8 Kw	8 Kw	12 Kw
Pressione di chiusura / Closing pressure / Schliessdruck / Effort de soudure / Presion de cierre	25.000 N	25.000 N	25.000 N

Materiali: vaschette preformate saldabili di mono o bicomponente, laminato, espanso, cartone ed alluminio con strato saldabile. / Materials: preformed sealable trays mono or bi-component, laminated, foam, cardboard and aluminium with sealable layer. / Material: vorgefertigte, siegelfähige Trays aus Mono- oder Verbundfolien, auch Schaummaterial, Karton- und Aluminiumtrays mit siegelfähiger Schicht. / Matériaux : barquettes scellables préformées mono ou bi-composant, en laminé, mousse, carton et aluminium avec couche scellable. / Materiales: tanques preformados soldables de uno o dos componentes, laminado, espuma, cartón y aluminio con capa soldable.

TECNOVAC s'ri riserva la facultat de apporter modifiacii sau modificari la facultat de apporter a nos constructii sau domeniilor amelioratilor/TECNOVAC se reserva el derecho de modificar sin previo aviso. * La pompa standard non puo lavorare con un % de O₂ > 21%/* The standard pump cannot work with % of O₂ > 21%/* La pompe à vide ne peut pas travailler avec un % de O₂ > 21%/* Die standardvakuumpumpe kann nicht mit einem % O₂ von Sauerstoff über 21 %/* La bomba estandard no puede trabajar con un % de O₂ > 21%. ** Il compressore non è incluso/** Compressor is not included/** Der druckluftkompressor ist nicht inbegriffen/** El compresor no está incluido.

HEADQUARTER

Via Padre Elzi, 28/C
24050 GRASSOBBIO (BG)
ITALY

Tel. (+39) 035 3846801/02/03 - (+39) 035 534074
Fax (+39) 035 534076



USA

2106-C Cheshire Way
Greensboro, NC 27405
USA
Tel. (+1) 336-375-8822
Fax (+1) 336-464-2330

ARGENTINA

Pte Luis Saenz Peña 1831 Piso 1
(1135) C.A.B.A.
ARGENTINA
Tel. (+54) 11 4304-2845

BRASILE

Alameda Jurua, 105 - Galpao 4
Alphaville, Barueri - SP - 06455-010
BRASIL
Tel. (+55) 11 4688 0682
Fax (+55) 11 4689 1161

MIDDLE EAST

205 Christodoulou Hadjipavlou Str
Loulloupis Court - 5th Floor, Office 501
3036 Limassol
CYPRUS
Mobile: (+961) 3253741

info@tecnovac.com - www.tecnovac.com